

# Cormac 2 Stainless Steel



### Description

MacArtney Cormac winches are modular and self-contained in protective frames. They are constructed from glass blasted AISI 304 stainless steel and require minimal maintenance.

They are designed to be easy to control either by using the controls mounted on the frame or by remote. The electric motor and junction box are IP56 and fitted with a direct drive level wind.

The “soft start” function makes the winch easy to handle, improves equipment manoeuvrability and protects the winch motor and gear.

The Cormac 2 Stainless Steel electrical oceanographic winch is designed for 800 m of 11.4 mm diameter cable. The unit is prepared for a Focal model 180 electrical/electro-optical slip ring.

### Features and benefits

- All structural components in stainless steel
- Minimal maintenance
- Integrated protection frame
- Protective grating
- Frame mounted control panel
- Direct driven level wind
- Long proven track record

### Applications

- Side scan sonar systems
- ROV systems
- Oceanographic profiling CTD systems

### System options

- Stainless steel junction box
- Remote control with variable speed
- Joystick, IP56
- Vibration absorbing installation brackets
- Cable status indicator showing deployment length and speed
- Electro-optical slip ring (Focal 180 size)
- CE marking
- Canvas cover
- Available in AISI 316



03-2012

# Technical Specifications

## Specifications

### Winch dimensions

Depth: 1100 mm  
 Height: 995 mm  
 Width: 1050 mm

### Drum dimensions

Drum diameter: 400 mm  
 Flange diameter: 700 mm  
 Length: 443 mm

### Speed/pull 1<sup>st</sup> layer

Line pull: 3.6 kN  
 Speed: 0-28 m/min

### Motor size

Motor size: 2.2 kW, 3x400/440 V

Weight: 342 kg

Specification subject to change without notice

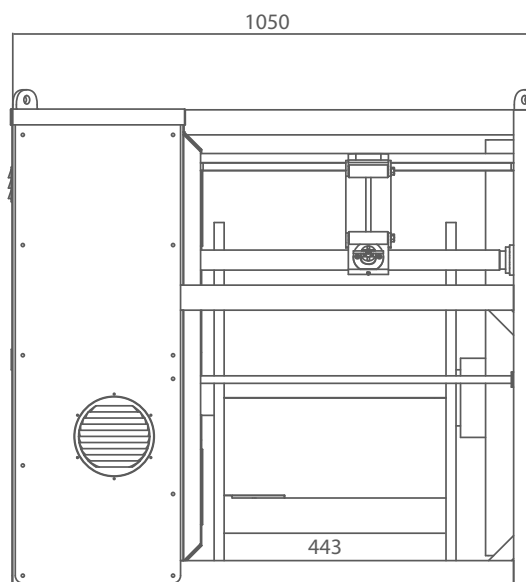
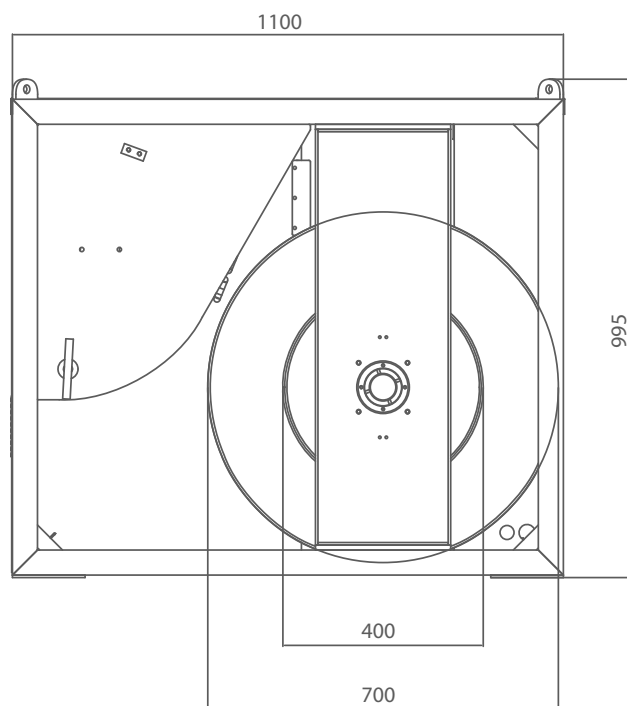

Cable diameter (mm)	Cable length (m)	Pull top layer (kN)
6.4	2700	2.2
8.2	1500	2.2
11.4	800	2.3
12.6	600	2.3

Measurements for tension spooled steel armoured cable.